

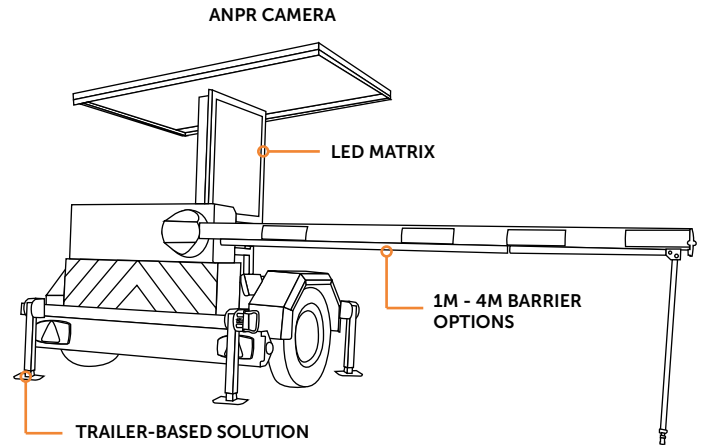

SALE & HIRE SOLUTION

ENHANCE SITE SECURITY & PREVENT UNAUTHORISED ACCESS



TRAILER

- Overall length: 2420mm (1620mm with towing tongue removed)
- Width (travel position): 1620mm – 1595mm
- Width (operating position): 1620mm
- Width (with Barrier): 2620mm - 5620mm
- Height (travel position): 2045mm
- Height (max operating position): 3200mm
- Height (with Barrier): 2200mm - 6200mm
- Weight: 600kg
- Coupling: 40mm towing eye

DISPLAY

- Display Type: LED full matrix
- Display Size: 680mm x 780mm
- Communication: SMS, internet, satellite, web-based, serial and App
- Matrix: 28 x 28
- Brightness Control: Automatic or manual

IDEAL FOR:



MESSAGING



WARNINGS



REMOTE CONTROLLED OPTION



ANPR CAMERA

Buy or hire our Incursion VMS Barrier to enhance site security and prevent unauthorised access. The system is simple to set up; upload your vehicle whitelist to the ANPR camera either locally or remotely. As vehicles approach, the camera identifies number plates and checks whether they are authorised.

Approved vehicles trigger the barrier to open, and the screen displays clear messages such as "Welcome to site", "Drive safe", or speed roundels as a final safety reminder. Unauthorised vehicles are stopped, giving you controlled and reliable site access management.

